



InstruTech[®], Inc.

Series 400 Hornet™ Hot Cathode Bayard-Alpert Miniature-Ionization Vacuum Gauge

Wide measurement range

1×10^{-9} to 5×10^{-2} Torr
 1.3×10^{-9} to 6.7×10^{-2} mbar
 1.3×10^{-7} to 6.7 Pa

Full range measurement from

1×10^{-9} Torr to atmosphere when
used with the B-RAX or the FlexRax
controllers and a convection gauge

Ionization gauge designed specifically
for use with InstruTech's B-RAX or
FlexRax vacuum gauge controllers

*Dual hot filament design, rugged
and compact metal construction*

Significant cost savings compared to
other vacuum gauge measurement
systems

*Built-in Electrometer results in
significant controller and cabling
cost reduction*



Description

The IGM400 *Hornet*™ is a hot cathode ionization gauge module specifically designed for use with InstruTech's B-RAX™ or FlexRax™ vacuum gauge controllers.

All display and control functions are performed remotely by the B-RAX or the FlexRax controller.

The InstruTech IGM400 Hornet Ionization Gauge

The IGM400 *Hornet* ionization vacuum gauge module (IGM) provides the basic signal conditioning required to turn the gauge into a complete measuring instrument.

The emission current can be set to automatically switch between 4 mA and 100 μ A. This results in optimal and stable pressure readings over the entire measurement range from low to high vacuum.

InstruTech continuously strives to enhance the design, reduce cost and improve the performance and reliability of the *Hornet* IGM. The electrometer circuit auto zeroes to ensure that the readings are not subject to temperature drift, eliminating the need for unnecessary and expensive circuitry which further reduces the cost.

The IGM400 *Hornet* gauge tube assembly is constructed of a compact all metal design with dual yttria coated Iridium or optional dual tungsten filaments.

The IGM400 *Hornet* is functional only when used with the B-RAX or the FlexRax vacuum gauge controller. This allows the user to remotely operate the IGM400 *Hornet* from the B-RAX or the FlexRax controller.

For general vacuum applications, dual yttria coated filaments are offered for use with air and inert gases such as N₂, argon, etc. Dual tungsten filaments are available for use with gases that may not be compatible with yttria coated filaments.

All operations including filament on/off, degas, and change of emission current is controlled from the B-RAX or the FlexRax.

The gauge sensor assembly can be easily replaced in the field.

Specifications

measurement range	1×10^{-9} to 5×10^{-2} Torr / 1.3×10^{-9} to 6.7×10^{-2} mbar / 1.3×10^{-7} to 6.7 Pa
accuracy - N ₂ (typical)	1×10^{-8} to 5×10^{-2} Torr; $\pm 15\%$ of reading
repeatability - (typical)	$\pm 5\%$ of reading
materials exposed to gases	dual Filaments: yttria coated iridium or optional tungsten Ion collector: tungsten Grid: tantalum Others: 316/304 SS, glass, nickel
sensitivity	factory pre-set. Also user adjustable from 2 to 99 (set by the B-RAX or the FlexRax)
x-ray limit	$< 5 \times 10^{-10}$ Torr, $< 6.7 \times 10^{-10}$ mbar, $< 6.7 \times 10^{-8}$ Pa
emission current	100 μ A, 4 mA, or automatic switching between 100 μ A and 4 mA
degas	3 W, electron bombardment
overpressure protection	gauge is auto turned off at factory default setting of 5×10^{-2} Torr B-RAX or FlexRax can also be set up to auto filament turn on/off using a convection gauge
filament status	filament on/off status is determined by LED on the IGM400 and also display messages and available user interface options on the B-RAX and FlexRax controllers
internal gauge volume	1.0 in ³ (16.4 cm ³)
temperature	operating; 0 to + 40 °C storage; -40 to + 70 °C
bakeout temperature	200 °C (sensor only - electronics removed)
humidity	0 to 95% relative humidity, non-condensing
weight	0.6 lb. (0.27 kg) with NW25 KF flange
housing (electronics)	aluminum extrusion
mounting orientation	any
setpoint relay	relays available from the B-RAX or the FlexRax
input signal	all IGM400 operations controlled from the B-RAX or the FlexRax
filament selection	user selectable between filament 1 and 2 - command signal sent from the B-RAX or FlexRax
input power	powered by B-RAX or the FlexRax
connector/cabling	InstruTech cable/connector assembly for connection to B-RAX or the FlexRax
CE compliance	EMC Directive 2004/108/EC, EN61326-1, EN55011 Low Voltage Directive 2006/95/EC, EN61010-1
Environmental	RoHS compliant

Fitting	dimension A
NW16KF	1.45 in. (37mm)
NW25KF	1.45 in. (37mm)
NW40KF	1.45 in. (37mm)
1 1/3 in. Mini-CF	1.85 in. (47 mm)
2 3/4 in. Conflat®	1.70 in. (43 mm)
3/4 in. Tube	2.16 in. (55 mm)
1/2 in. VCR	2.58 in. (65 mm)

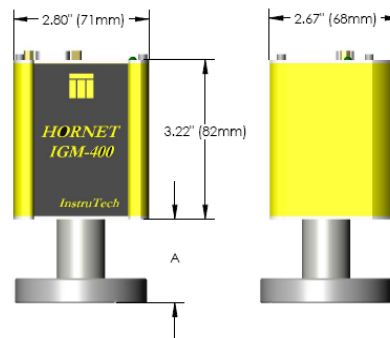

Ordering Information

Part Numbers

IGM400 Fittings / Flanges	Yttria Filaments	Tungsten Filaments	Replacement / Spare Sensor - Yttria	Replacement / Spare Sensor - Tungsten
NW16KF	IGM400YBX	IGM400TBX	IG4YB	IG4TB
NW25KF	IGM400YCX	IGM 400TCX	IG4YC	IG4TC
NW40KF	IGM400YDX	IGM400TDX	IG4YD	IG4TD
1 1/3 in. Mini-CF/NW16CF Mini-Conflat®	IGM400YEX	IGM400TEX	IG4YE	IG4TE
2 3/4 in. CF / NW35CF Conflat®	IGM400YFX	IGM400TFX	IG4YF	IG4TF
3/4 in. Tube (3/4 in. O.D. O-ring compression)	IGM400YAX	IGM400TAX	IG4YA	IG4TA
1/2 in. Cajon® 8VCR® female	IGM400YHX	IGM400THX	IG4YH	IG4TH

B-RAX or FlexRax Controller & Gauge Cables - see B-RAX or FlexRax controller data sheet

Conflat® is a registered trademark of Varian, Inc. / Agilent Technologies, Lexington, MA.

Swagelok®, Cajon®, VCR® are registered trademarks of the Swagelok Company, Solon, OH.



InstruTech®, Inc.
1475 S. Fordham Street
Longmont, CO 80503
USA

Phone +1-303-651-0551
Fax +1-303-678-1754
E-mail info@instrutechinc.com
Web www.instrutechinc.com